

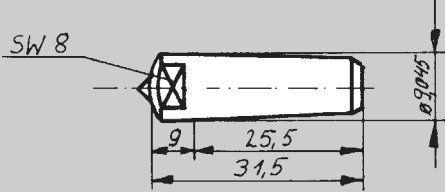

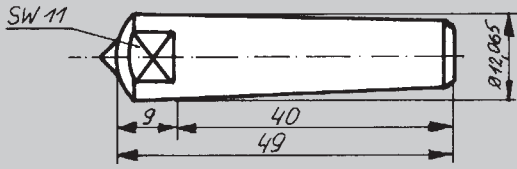

 Einkorn Abricht- Diamanten	Best. Nr.	Fassung	Karat
	A 100		0,10/0,30/0,50/0,75/1,00/1,50/2,00/
	A 105		0,10/0,30/0,50/0,75/1,00/1,50/2,00/
	A 110		0,10/0,30/0,50/0,75/1,00/1,50/2,00/
	A 115		0,10/0,30/0,50/0,75/1,00/1,50/2,00/
	A 120		0,10/0,15/0,20/

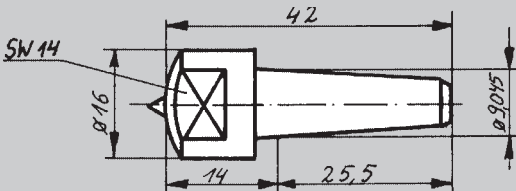
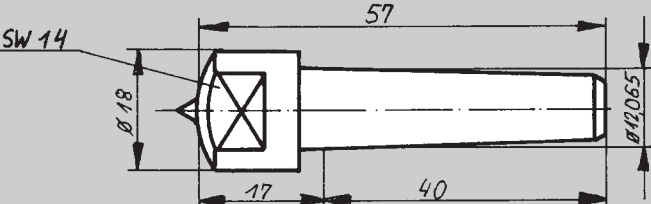
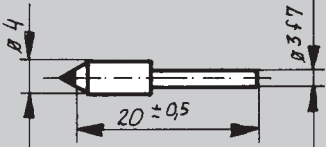

	Best. Nr.	Fassung	Karat
 <p data-bbox="150 685 373 846">Einkorn Abricht- Diamanten</p>			
	A 125	Form D	0,10/0,30/0,50/0,75/1,00/
			
	A 130	Jung Kegel 1:20	0,10/0,30/0,50/0,75/1,00/
			
	A 135	Jung Kegel 1:13,15	0,10/0,30/0,50/0,75/1,00/
			
	A 140	Jung Kegel 1:13,15	0,10/0,30/0,50/0,75/1,00/
			
A 145	Form E	0,10/0,30/0,50/0,75/1,00/	

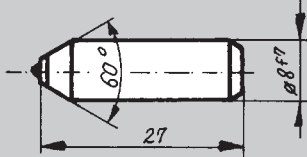
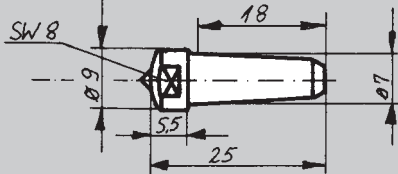
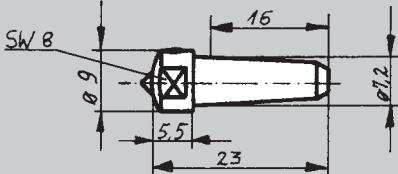
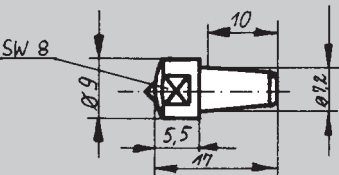
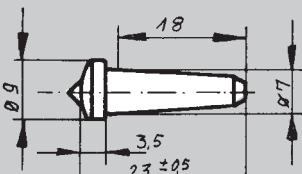
	Best. Nr.	Fassung	Karat
 Einkorn Abricht- Diamanten			
	A 150	Jung Kegel 1:10	0,10/0,30/0,50/0,75/
			
	A 155	Kolb Kegel 1:50	0,10/0,30/0,50/0,75/
			
	A 160	ABA	0,10/
			
	A 165	ABA	0,10/0,30/
			
A 170	Form D	0,10/0,30/0,50/0,75/	

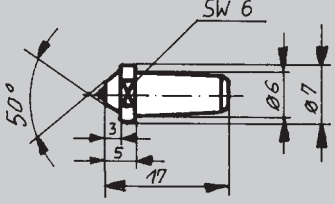
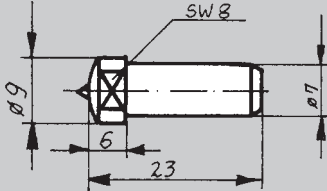
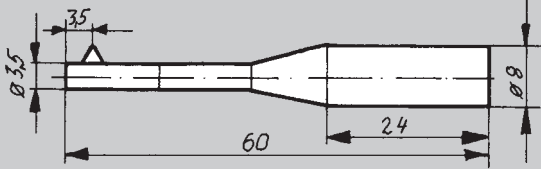
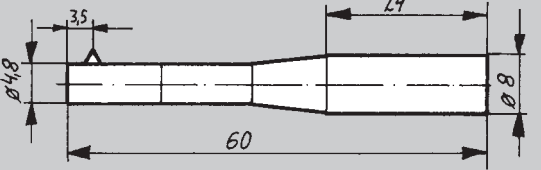
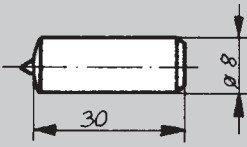

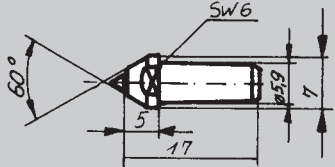
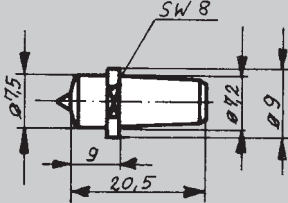
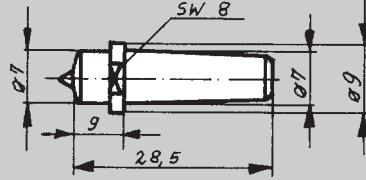
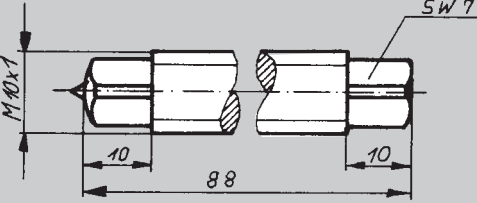
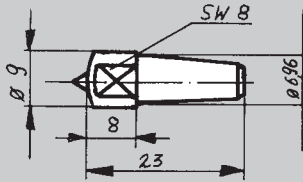
	Best. Nr.	Fassung	Karat
 <p data-bbox="146 683 375 851">Einkorn Abricht- Diamanten</p>			
	A 175	Jung Kegel 1:10	0,10/0,30/0,50/0,75/
			
	A 180	Jung Kegel 1:13,15	0,10/0,30/0,50/0,75/
			
	A 185	Jung Kegel 1:20	0,10/0,30/0,50/0,75/
			
	A 190	Niles	0,10/0,30/0,50/0,75/
			
A 195	Kolb	0,10/0,30/0,50/0,75/	

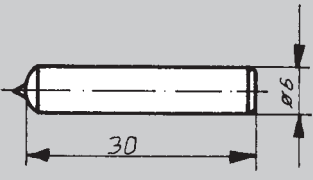
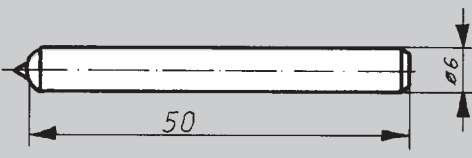
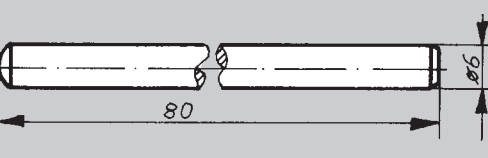
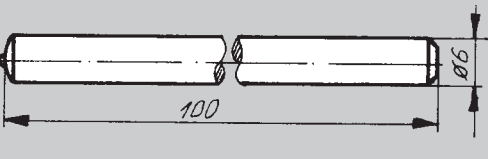
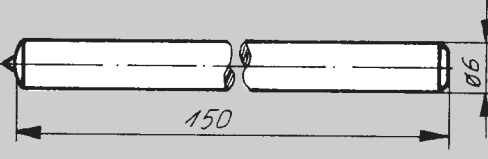

 Einkorn Abricht- Diamanten	Best. Nr.	Fassung	Karat
			
	A 225	Form D	0,10/0,30/0,50/
			
	A 230	Form D	0,10/0,30/0,50/
			
	A 235	Form D	0,10/0,30/0,50/
			
A 240	Form D	0,10/0,30/0,50/	
			
A 245	Form D	0,10/0,30/0,50/	

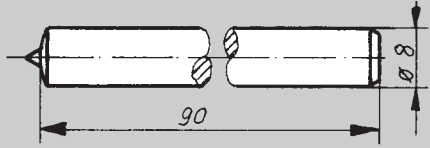
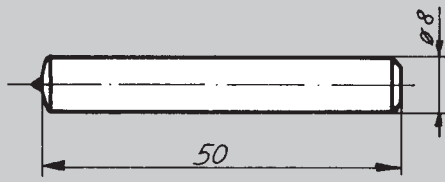
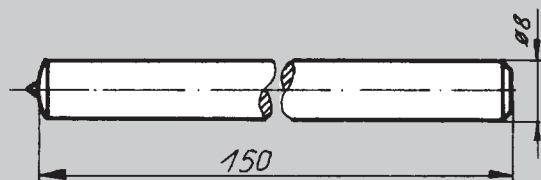
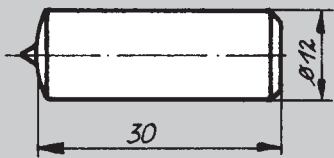

	Best. Nr.	Fassung	Karat
 <p>Einkorn Abricht- Diamanten</p>			
	A 220	Deckel	0,10/0,30/0,50/0,75/
			
	A 250	Form D	0,10/0,30/0,50/0,75/
			
	A 255	Form D	0,10/0,30/0,50/0,75/
			
A 260	Form D	0,10/0,30/0,50/0,75/1,00/1,50/2,00/	

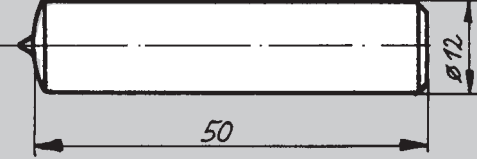
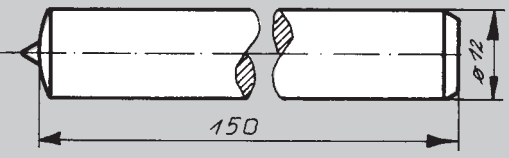
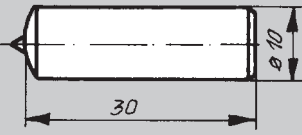
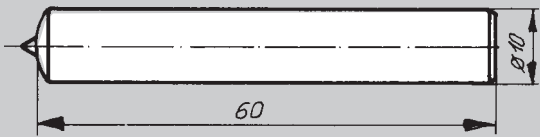
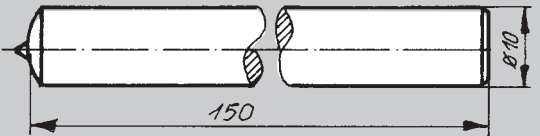

Einkorn
Abricht-
Diamanten

Best. Nr.	Fassung	Karat
		
A 265	Form D	0,10/0,30/0,50/0,75/1,00/1,50/2,00/
		
A 270	Form D	0,10/0,30/0,50/0,75/1,00/1,50/2,00/
		
A 275	Form D	0,10/0,30/0,50/0,75/1,00/1,50/2,00/
		
A 280	Form D	0,10/0,30/0,50/0,75/1,00/1,50/2,00/
		
A 285	Form D	0,10/0,30/0,50/0,75/1,00/1,50/2,00/



2







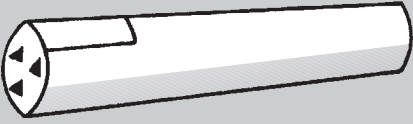

Geschliffene
Abricht-
Diamanten

Best. Nr.	Fassung	Karat
A 290	Dachform MK 0	0,50 – 1,00
A 295	Dachform MK 1	0,75 – 1,50
		<p>L = 45,5 mm α = 40°; 60° R = 0,125 mm; 0,250 mm; 0,500 mm</p>
A 310	Diaform	0,33 – 0,50



B

Mehrkorn
Abricht-
Diamanten

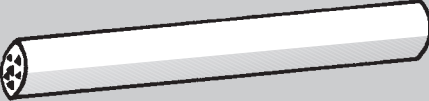
Best. Nr.	Fassung	Steine	Best. Nr.	Fassung	Steine
					
A 320	MK 1	3	A 325	MK 0	3
					
A 330	8 x 90	3	A 335	MK 1	3
					
A 340	MK 0	3	A 345	8 x 90	3
					
A 350	MK 1	6	A 355	MK 0	6
					
A 360	8 x 90	6			



4





Vielkorn
Abricht-
Diamanten
"gesintert"

Best. Nr.	Fassung	Karat
A 365	VKMK 0	1,25
A 370	VKMK 1	2,20
A 375	VK \varnothing 8	0,85
A 380	VK \varnothing 10 mit Bund	3,45
	Körnung D 1001 D 181 D 711 D 126 D 602 D 91 D 426	



5

Hand
Abricht-
Diamant
"gesintert"

Best. Nr.	Stirnfläche mm	Karat
		
070	10 x 20	1,5
		
071	10 x 30	2,0
		
072	10 x 40	3,0
		
073	10 x 30	1,5
		
074	10 x 30 / 2x	3,0